

## Variable Air Volume Modular Assembly (VMA) 1400 Series Overview and Engineering Guidelines

<b>VMA1400 Series Overview and Engineering Guidelines .....</b>	<b>2</b>
<b><i>Introduction.....</i></b>	<b>2</b>
<b><i>Key Concepts.....</i></b>	<b>3</b>
VMA1400 Series Models.....	3
VAV System .....	6
Definition of Terms .....	9
Room Sensor Placement .....	10
Pressure Independence .....	10
VMA Airflow Rate .....	10
Power Source.....	11
N2 Bus Rules .....	12
Inputs and Outputs.....	13
Zone Bus.....	14
CablePRO .....	15
CVTPRO .....	15
Related Documentation.....	16
Application Examples.....	17
Reference Information.....	26
Specifications .....	27
<b><i>Detailed Procedures.....</i></b>	<b>32</b>
Determining VAV Box Requirements .....	32
Establishing the Room Schedule .....	32
Developing the Bill of Material and Placing Orders.....	33
Configuring the VMA .....	35

# VMA1400 Series Overview and Engineering Guidelines

## ***Introduction***

The Variable Air Volume Modular Assembly (VMA) 1400 Series is a configurable, integrated module that includes a Variable Air Volume (VAV) controller, differential pressure sensor, and, with the exception of the VMA1430, an actuator.

**Note:** This document focuses on the VMA1410, 1420, and 1430 controllers. The VMA1400 Series also includes the VMA1440, which is used exclusively as part of the Metasys® Zoning Package. See the *Metasys Zoning Package Product Bulletin (LIT-639050)* and the *Metasys Zoning Package Overview Technical Bulletin (LIT-639100)* for information on this specialized product.

The VMA engineering procedures vary from location to location. The information provided here is a general engineering guideline. Where available, use the Advanced Installation Management (AIM) tools for developing schedules and drawings.

This document provides a VMA1400 Series overview and describes how to:

- determine VAV box requirements
- establish the room schedule
- develop bills of material and place orders
- configure the VMA

## Key Concepts

### VMA1400 Series Models

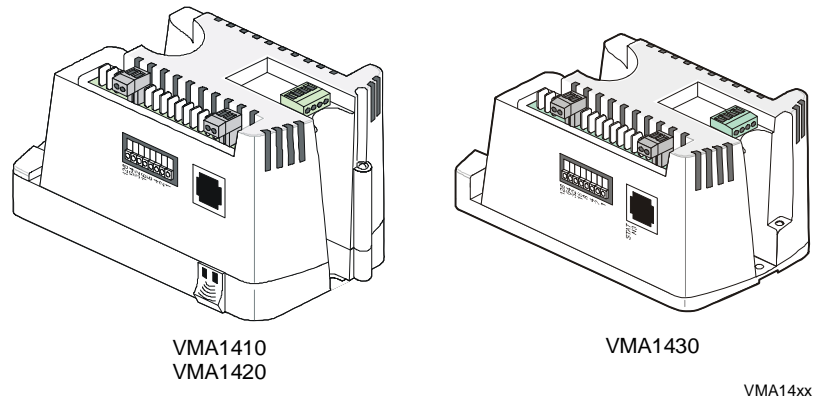

**Figure 1: VMA1400 Series Models**

The VMA is a configurable, integrated module that includes a VAV controller and differential pressure sensor. The VMA1400 Series includes three models:

VMA1410 (cooling only, includes actuator)

VMA1420 (cooling with reheat, includes actuator)

VMA1430 (controller and differential pressure sensor only for use with an external incremental or proportional actuator)

**Note:** The VMA1400 Series also includes the VMA1440, which is used exclusively as part of the Metasys Zoning Package. See the *Metasys Zoning Package Product Bulletin (LIT-639050)* and the *Metasys Zoning Package Overview Technical Bulletin (LIT-639100)* for information on this specialized product.

The models are designed for pressure independent, single duct (all VMA1400 Series models), and dual duct (VMA1420 and 1430 only) applications. The VMA1420 and 1430 models can be used with parallel or series fan-powered boxes.

**Note:** The VMA1420 can be configured for the Metasys Zoning Package application, but the internal pressure sensor can only be used for monitoring purposes. Refer to the *Metasys Zoning Package Commissioning Technical Bulletin (LIT-639250)*.

Table 1: VMA1400 Series Comparison Checklist

VMA Features	1410	1420	1430	Comments
<b>Applications</b>				
Pattern Recognition Adaptive Control (PRAC) on Zone Proportional plus Integral plus Derivative (PID) Temperature Loops	Y	Y	Y	Eliminates manual tuning and seasonal re-tuning
Adaptive Flow Control Loops	Y	Y	Y	Eliminates manual tuning, improves control and energy savings
Single Duct, Pressure Independent VAV	Y	Y	Y	Meets most VAV applications
Side Loops without Interlocking	N	Y	Y	Single Analog Input (AI) to Analog Output (AO) or Binary Output (BO)
Single Duct Supply/Exhaust VAV	N	Y	Y	Flow differential control
Fan Powered Boxes	N	Y	Y	Series or parallel
Incremental, Proportional Two Position, and Three Stages of Box Heat	N	Y	Y	Staged heat or normally open/normally closed valves
Incremental, Proportional Two Position, or One Stage Supplemental Heat	N	Y	Y	Normally open or closed valves
Dual Duct, Pressure Independent VAV	N	Y	Y	Flexible flow setpoint specification
<b>Damper Actuator (Internal)</b>				
Accurate Positioning	Y	Y	N/A	23,000 step resolution
Stall Detection	Y	Y	N/A	Detects damper travel stops
Automatic Damper End Stop Detection at Power Up	Y	Y	N	Sets damper stroke time
Clockwise (CW)/ Counterclockwise (CCW) Rotation Selection	Y	Y	Y	Set via HVAC PRO™ software for either direction to close
EP8000 with Pneumatic Actuator	N	Y	Y	
<b>Software Tools</b>				
Ability To Download Code Firmware	Y	Y	Y	Allows firmware code upgrade without removing the VMA
<b>Diagnostics</b>				
Moving Average Flow/Temperature Diagnostic	Y	Y	Y	Provides standard measure of control loop performance over time
Actuator Stall	Y	Y	N/A	
Flow Test	Y	Y	Y	
Data Graphing	Y	Y	Y	Only for single duct applications
Starved Box Detection	Y	Y	Y	Allows air handler reset and flow diagnostics
Actuator Duty Cycle Diagnostic	Y	Y	Y	Indicates shaft slippage
Continued on next page . . .				

<b>VMA Features (Cont.)</b>	<b>1410</b>	<b>1420</b>	<b>1430</b>	<b>Comments</b>
<b>Commissioning</b>				
<b>Balancing Tool with Automatic Pickup Gain Calculation</b>	Y	Y	Y	HVAC PRO software (single duct only) or VMA Balancing Tool (VBT) software on Zone Bus
<b>Hardware</b>				
<b>24 Volts Alternating Current (VAC) Isolation Built-in</b>	Y	Y	Y	Eliminates 24 to 24 VAC transformer and polarity concerns
<b>Multiple VMAs per 100 VA Transformer</b>	Y	Y	Y	Ten cooling only (VMA1410) or 14 VMA1430s. Reheat/fan unit depends on valve/fan relays
<b>Isolated N2, Binary Outputs, and 24 VAC</b>	Y	Y	Y	Saves installed cost and improves electrical noise rejection
<b>Ability to Drive Low Current Relays Down to 25 milliamperes (mA)</b>	N	Y	Y	Eliminates relay chatter
<b>15 Bit Analog Input/12 Bit Analog Output Resolution</b>	AI only	Y	Y	Provides improved control device resolution
<b>Analog Input Jumpers Eliminated</b>	Y	Y	Y	Reduces labor because all analog inputs are preset
<b>Differential Pressure Transducer</b>				
<b>Dead Ended Transducer</b>	Y	Y	Y	Requires no filters or maintenance
<b>Stainless Steel Capacitive Technology</b>	Y	Y	Y	Provides improved stability
<b>Industry Accepted Flow Measurement Accuracy</b>	Y	Y	Y	Provides stability below 1 m/s (200 fpm)
<b>Temperature Sensors</b>				
<b>Variety of Sensors</b>	Y	Y	Y	Nickel, 1 K platinum, silicon, 2.25K NTC
<b>Temporary Occupied Button</b>	Y	Y	Y	On TE-6700, TE-7000 (Europe only), and TMZ1600 Series room sensors
<b>Temporary Occupied Light-Emitting Diode (LED)</b>	Y	Y	Y	On TE-6700, TE-7000 (Europe only), or TMZ1600 for timed override (Temporary Occupied)
<b>LED Indicator for N2/Power</b>	Y	Y	Y	Verifies N2 and power connections
<b>Physical</b>				
<b>Small, One Piece Assembly: VMA1410, VMA1420 152.4 x 101.6 x 101.6 mm (6 x 4 x 4 in.) VMA1430 152.4 x 101.6 x 82.6 mm (6 x 4 x 3.25 in.)</b>	Y	Y	Y	Reduces installation cost
<b>Plenum Plastic Housing Rating</b>	Y	Y	Y	Underwriters Laboratories®, Inc. (UL) 94-5VB plenum flammability eliminates metal box
<b>Removable I/O Screw Terminals</b>	Y	Y	Y	Two or three position accessories

## VAV System

### *Theory of Operation*

A VAV air handling system typically consists of a single air handling unit and multiple terminal units. Terminal units typically consist of a damper and flow sensing probe installed in an enclosure. VAV terminal units are also called VAV boxes. VAV systems are predominantly single duct, but about 15% are dual duct designs. In either case, the supply air temperature and static pressure of the air handling unit are controlled by an AHU (Air Handling Unit) controller, while each zone has its own VMA controller.

The air handling unit typically maintains a static pressure in the range of 125 to 375 Pa (0.5 to 1.5 inches water column (w.c.) inside the longest run of duct away from the supply fan. This ensures that each VAV terminal unit has enough pressure at its inlet to deliver the maximum required flow of air into the space. The supply temperature is typically in the range of 7 to 16°C (45 to 60°F) for a single duct VAV system or the cold deck of a dual duct VAV system. The hot deck temperature of a dual duct VAV system is typically in the range of 29 to 49°C (85 to 120°F).

VAV systems are most easily understood by first considering a cooling-only application. As the zone temperature increases, the VAV controller opens the VAV box damper to allow more cool air to reach the space. The volume of air required to maintain a particular zone temperature setpoint is dictated by the size of the space and the internal and external heat loads. In addition, since the size of the VAV box dictates its maximum cooling capacity, a VAV box's performance is dependent upon the mechanical engineer's correct box sizing for each zone.

Sometimes the size, and thus the capacity, of the VAV box may not match the zone loads. If the installed unit is too small, insufficient cooling results and noise may be emitted at high flow. If the installed unit is too large, proper control may be difficult to attain, since a small change in damper position causes a large change in airflow. Boxes can be oversized to allow for quieter operation or reserve cooling capacity at the expense of controllability.

The VMA quickly adjusts the damper position to new conditions, and minimizes position hunting and motor runtime. The fast response stepper actuator on the VMA1410 and 1420 drives the damper from full open to full closed in 30 seconds. This significantly reduces the time to commission a VAV box. Response time of the VMA1430 with an external synchronous actuator is dependent upon the speed of the actuator used. The VMA incorporates flow feedback to accurately position the damper. Control performance metrics are recorded and are available via the Metasys Operator Workstation (OWS) for timely indication of system problems.

The VMA is configured for most VAV applications. Configuration Tools (HVAC PRO software), Version 7.00 or later builds the applications for VMA1410/1420. Version 7.02 or later includes the VMA1430 as well as the VMA1410/1420.

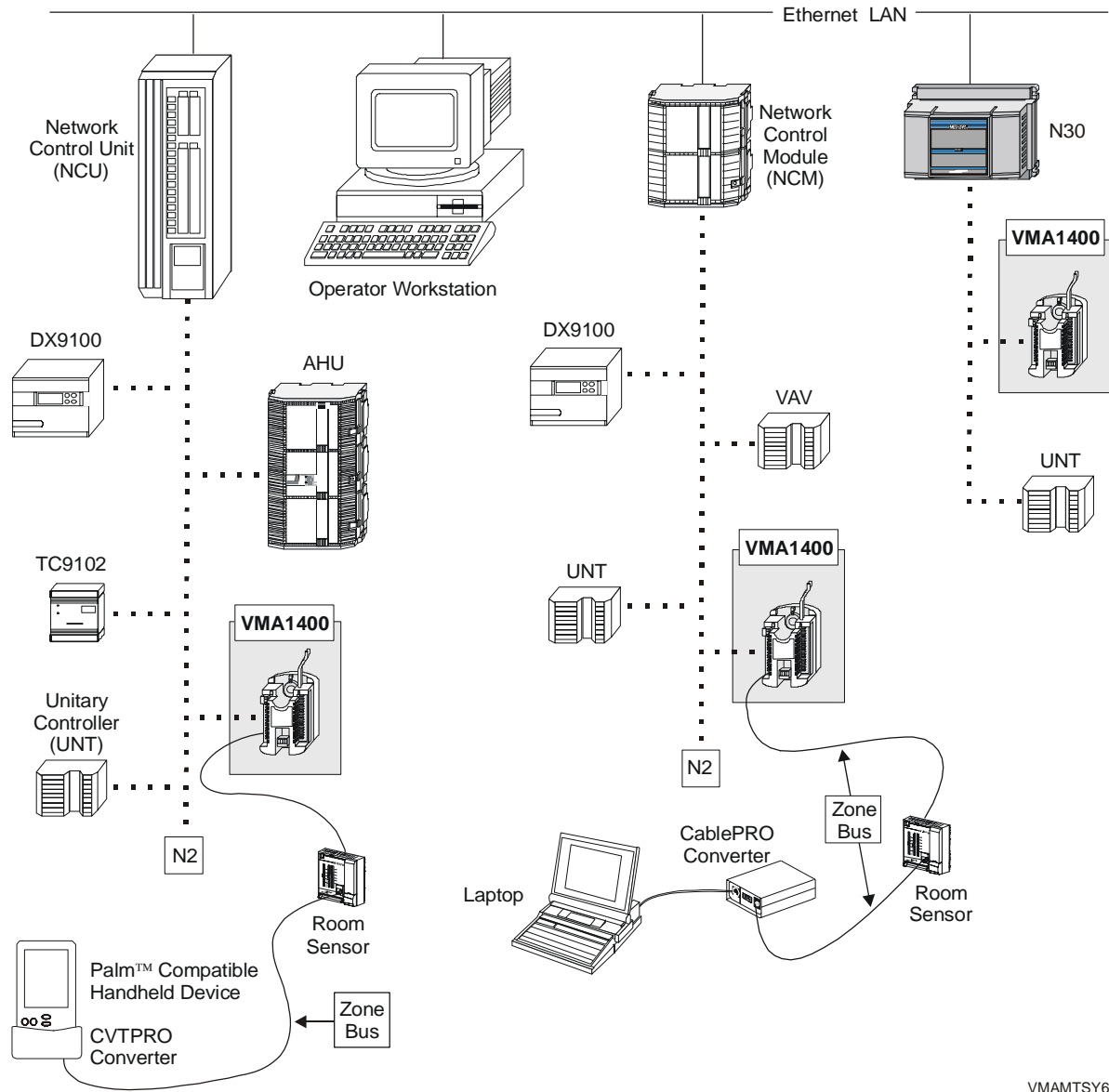

VMAMTSY6

Figure 2: VMA in Metasys Network Diagram



## Definition of Terms

### ***Autocalibration***

To correct for pressure sensor drifts over time, the VMA has an Autocalibration mode that automatically compensates for temperature and humidity effects.

### ***N2 Switches***

Single-pole, single-throw switches used to set the N2 address of a controller.

### ***Room Schedule***

A set of information listing all parameters required in a room or zone.

### ***Test and Balance (TAB)***

Test and Balance (TAB) is a function performed to ensure the installed system operates to design specifications. Balancing of the VMA zone indicates whether the VAV terminal box is able to achieve minimum/maximum airflow settings. TAB must also be performed for the air handler and the air duct distribution to the VAV box.

### ***Zones***

When designing VMA systems, it is critical to establish zones correctly to take full advantage of VMA's exceptional accuracy and rapid response capabilities.

The designer strives for the most uniform indoor environmental conditions possible. A single thermostatic device (room sensor) controls each area. Also, you may consider a zone any area where the load is approximately the same for every square foot of floor space.

Heating, Ventilating, and Air Conditioning (HVAC) system zones fall into two major categories: exterior zones and interior zones. Exterior zones are spaces directly affected by outdoor weather conditions. Interior zones are not influenced by heat losses or outdoor air conditions. Interior zones usually have cooling or ventilation requirements only.

Further division of interior/exterior zones is occasionally required to accommodate different occupancy schedules and/or solar loads. Variations in internal loading also dictate the selection of separate zones. For example, in a restaurant, the kitchen has much different heating and cooling requirements than the customer seating area.

## Room Sensor Placement

When considering room sensor placement for each zone:

- Verify that the room sensor is the correct one for the application.
- Review architectural requirements such as furniture height and location, aesthetics, and type of mounting. Wall plates are required if mounting on a conduit handibox.
- Review room sensor location. The best room sensor location is on an interior wall, about 1.5 m (5 feet) above the floor, out of direct sunlight, out of the direct path of supply air from the diffuser, away from heat sources, such as equipment, machines, and perimeter radiation, and away from doors and other draft sources. Local codes or disabilities act requirements occasionally influence the actual mounting height.
- Do not locate a sensor near zone boundaries, where primary influence is from an adjacent zone.

## Pressure Independence

The pressure independent VMA employs patented self-tuning, cascaded proportional/integral control loops. The zone temperature loop samples space temperature and resets the airflow setpoint between the minimum and maximum flow settings. Since inlet duct static pressure influences the amount of air passing through the VAV box, the VMA airflow loop samples airflow via a flow pickup in the box inlet. It modulates the damper to control the flow. Thus, the VAV box flow is independent of duct static pressure.

The engineering basis for this method of control is that the temperature of a space with a constant load is linearly proportional to the flow of conditioned air into the space. The engineer must accurately determine the required maximum and minimum flow for each space based on heating, cooling, and ventilation loads.

## VMA Airflow Rate

The VMA determines airflow rate by dynamic pressure measurement. The VMA contains a Differential Pressure Transducer (DPT) to sense velocity pressure in pressure independent VAV applications.

The DPT is connected to the VAV box airflow pickups. It measures velocity pressure and generates a proportional voltage signal. The VMA reads voltage signal from the DPT and converts it to airflow in cubic feet per minute (cfm), liters/second, or cubic meters/hour. Calibration is not required, with the exception of zero calibration, which the controller performs automatically as set in the configuration.

The DPT provides maintenance-free performance within the control range of 1 to 18 m/s (200 to 3500 feet per minute [fpm]) when used as recommended.

Pressure independent VAV terminal boxes use an airflow pickup device, which amplifies the airflow velocity pressure between 1.5 to 3 times (varies by manufacturer). The airflow velocity and the gain of the airflow pickup produce an accurately measured pressure difference.

The VMA Autocalibration function helps reduce the temperature effect error by zeroing offset errors. As the ambient temperature swings relative to the temperature at which the Autocalibration occurred, an offset error occurs. In the worst case, the offset error ranges up to  $\pm 0.179$  Pascal per  $^{\circ}\text{C}$  ( $\pm 0.0004$  inch w.c. per  $^{\circ}\text{F}$ ). When calibration occurs, this error becomes zero.

The error envelope becomes smaller with increased airflow pickup gain and with smaller ambient temperature deviations at the transmitter location.

## Power Source

You can use one 24 VAC power trunk to power multiple VMAs. Transformers of up to 100 VA can be centrally located and the secondary run can be without conduit (if allowed by local authority) and without concern about polarity. When using a single transformer to power multiple VMAs, use a wire gauge large enough to handle the current and minimize the voltage drop. The voltage drop depends on the current draw, wire gauge, and wire length. For more details about transformer wiring and calculating the number of VMAs per transformer, see the *Mounting and Wiring Variable Air Volume Modular Assembly (VMA) 1400 Series Controllers Technical Bulletin (LIT-6363125)*.

**Note:** The 24 V power transformer must be UL/Canadian Standards Association (CSA) listed as NEC Class 2 Power Limited. See NEC Article 725/Class 2 (30 VRMS maximum) and (100 VA maximum).

## N2 Bus Rules

The N2 Bus is the interface between a supervisory controller (Metasys Network Control Module [NCM] or N30) and all application specific controllers in a Metasys Network. The VMA is self-terminating in that there are no End-of-Line (EOL) jumpers to set. However, you must set one EOL for each N2 Bus, usually at the NCM or N30. Table 2 summarizes the rules for installing the N2 Bus.

**Table 2: N2 Bus Rules**

<b>Category</b>	<b>Rules/Maximums Allowed</b>
<b>General</b>	Only one NCM or N30 per N2 Bus Only daisy-chained devices
<b>Maximum Number of Devices</b>	100 devices per NCM or 50 devices per N30 50 devices per repeater* Two repeaters cascaded
<b>Line Length and Type</b>	1500 m (5000 feet) between repeaters 4500 m (15,000 feet) maximum length (3 segments of 1500 m [5000 feet] each) 0.6 mm (24 American Wire Gauge [AWG]) twisted pair minimum (stranded 0.8 mm [22 AWG] twisted pair or heavier recommended)
<b>Terminations</b>	Two EOL devices per each segment that is longer than 100 m (330 ft) One EOL device at the controller for all segments regardless of length (required)

\* Add repeater after 49 devices. Count each repeater as one device.

## Inputs and Outputs

For specific input/output range, cable length, wire size issues, refer to the *Mounting and Wiring Variable Air Volume Modular Assembly (VMA) 1400 Series Controllers Technical Bulletin (LIT-6363125)*.

**Note:** All terminals are spade lug type except the N2 terminals, which are removable screw terminals. Optional two-, three-, or four-position kits (available for order) convert the spade lugs to removable screw terminals.

**Table 3: Inputs and Outputs**

<b>Input/Output</b>	<b>Description</b>
<b>Analog Inputs</b>	<p>There are two external and one internal analog inputs on the VMA1410 and four external and one internal analog inputs on the VMA1420 and 1430. They are preset for either temperature/setpoint or voltage. There are no jumpers to set. Shielding is not required, but if used, earth ground the shield only at the VMA. You may use 0.6 mm (24 AWG) twisted pair wire; however, this reduces the allowable wire length due to the resistance for Nickel (Ni), Platinum (Pt), or Silicon (Si) sensors. To minimize sensor error caused by field wiring, the total resistance of the nickel, silicon, or platinum resistive sensor wiring should be less than 3 ohms. The NTC sensor accepts a larger wire resistance. This wiring error effect can be corrected through HVAC PRO software in the VMAs analog input.</p> <p>Do not share the temperature/setpoint common wire (COM) with any other sensors, transmitters, or the Zone Bus. The maximum voltage drop on the common wire must be less than 1 mV.</p>
<b>Binary Inputs</b>	<p>There are three dry contact binary inputs on the VMA. An override button on the room sensor initiates a Temporary Occupancy or Time Override mode of operation when pressed. When using the TE-6700 or TE-7000 (Europe only) sensor, TempOcc shorts BI-1 directly. Hold for 2.0 seconds.</p> <p>The binary inputs on the VMA are inactive when open. They are active when you apply a contact closure to binary input common (COM).</p>
<b>Analog Outputs</b>	<p>There are two analog outputs on the VMA1420 and VMA1430. The VMA1410 has no analog outputs. The load connects between the analog output and analog output common (COM) terminals. Each output generates a proportional voltage output of 0 to 10 VDC. The maximum load for each output is 10 mA with a minimum load resistance of 1000 ohms. Note that two analog outputs are available on the VMA1430 for proportional reheat valves or a proportional damper actuator.</p>
<b>Binary Outputs</b>	<p>The VMA1410 has no external binary outputs. The VMA1420 and VMA1430 have five external binary outputs. The damper actuator wires internally to the VMA1410 and VMA1420. Each load connects between the BO terminal and BCOM common terminal. These outputs switch the transformer's low side to the output allowing the relays, actuators, or transformers to be earth grounded through Terminal 1 when needed to meet codes.</p> <p>A floating/3-wire (incremental) actuator wires externally to two of the five BOs on the VMA1430. There are only three BOs remaining for fan, box heating, supplemental heating, and lighting.</p>

## Zone Bus

The Zone Bus is a 2-wire communications bus that allows a computer to commission and balance the VMA's database. The computer must have the proper software and must connect through the CablePRO (AS-CBLPRO or IU-9100 in Europe) or CVTPRO (AS-CVTPROx00-x) converter and the room sensor. The VMA also supplies 15 VDC through the Zone Bus connector to power the CablePRO or CVTPRO converter.

**Note:** The VMA supplies 15 VDC instead of 24 VAC supplied by other Application Specific Controller (ASC) devices. The Zone Bus does not function properly if connected to 24 VAC on the VMA.

**Table 4: Zone Bus Specifications**

Feature	Specification
<b>Type</b>	Multi-drop serial communications bus, single ended (North America) or differential (Europe)
<b>Speed</b>	1200 baud (bits per second)
<b>Recommended Cable Type</b>	1.5 mm <sup>2</sup> (18 AWG) with or without shield (Beldon 8760) or 0.6 mm (24 AWG) without shield (unshielded telephone cable)
<b>Maximum Bus Length</b>	
<b>Single Ended</b>	150 meters (500 feet) with 1.5 mm <sup>2</sup> (18 AWG) cable 15 meters (50 feet) with 0.6 mm (24 AWG) cable
<b>Differential</b>	1500 meter (5000 feet) of 0.6 mm - 1.5 mm <sup>2</sup> (18-24 AWG) cable
<b>Voltages</b>	
<b>Single Ended</b>	
<b>Logic High Voltage</b>	4 VDC minimum (approximately)
<b>Logic Low Voltage</b>	1 VDC maximum (approximately)
<b>Differential</b>	
<b>Transmit</b>	±5 VDC
<b>Receive</b>	±0.2 VDC
<b>Data Transmission</b>	1 Start Bit (low level) 8 Data Bits (least significant bit first) 1 Stop Bit (high level)
<b>Isolation</b>	Isolated from 24 VAC, BOs, and N2 Bus

**Note:** Do not share the Zone Bus common wire with any other sensor or transmitter, as doing so can cause the VMA to misread the sensor value, resulting in poor control.

## CablePRO

CablePRO (AS-CBLPRO) is an interface device that is used between a computer or Palm™ compatible handheld device and the VMA. Use CablePRO for box balancing or commissioning via the Zone Bus communication port on the room sensor.

When used with a VMA, the CablePRO is strictly an electrical interface between the serial RS-232 port of the computer and the VMA. CablePRO operates on 15 VDC drawn from a VMA and provided through the Zone Bus. The data rate on both the RS-232 and the Zone Bus is 1200 baud.

The VMA connects to the RS-232 COM port of the computer via a DB9 or DB25 connector supplied with the CablePRO.

The diagnostic LEDs on the CablePRO indicate normal Zone Bus communications. The LEDs flash only when the VMA is transmitting or receiving data.

Refer to the *Auxiliary Gear Technical Bulletin (LIT-6363080)* for more information on the CablePRO.

## CVTPRO

CVTPRO (AS-CVTPROx00-x) is a Zone Bus/N2 Bus interface device that is used between a computer or Palm compatible handheld device and the VMA. Use CVTPRO for box balancing or commissioning via the Zone Bus communication port.

When used with a VMA, the CVTPRO is strictly an electrical interface between the serial RS-232 port of the Palm compatible handheld device and the Zone Bus. CVTPRO operates on 15 VDC, drawn from a VMA through the Zone Bus phone jack. The data rate on both the RS-232 and the Zone Bus is 1200 baud.

Refer to the *Auxiliary Gear Technical Bulletin (LIT-6363080)* for more information on the CVTPRO. For additional information on installing the AS-CVTPRO300-1 and ASCVTPRO400-1, refer to the *AS-CVTPRO300-1 and AS-CVTPRO400-1 Zone Bus/N2 Bus Interface Converters Installation Instructions (Part No. 24-10158-0)*.

## Related Documentation

Table 5 lists related VMA documentation.

**Table 5: Related Documentation**

<b>For Information on This</b>	<b>Use This Document:</b>
<b>Sales and Marketing Information</b>	<i>Variable Air Volume Modular Assembly (VMA) 1400 Series Product Bulletin (LIT-635058)</i>
<b>Downloading and Commissioning Details</b>	<i>HVAC PRO User's Guide</i>
<b>N30 Networking</b>	<i>N30 Supervisory Controller Networking Technical Bulletin (LIT-6891300)</i>
<b>Original Equipment Manufacturer (OEM) Issues</b>	<i>Appendix B: VAV Controller Flow Calculation Constants Application Note (LIT-6375185)</i>
<b>Configuration Choice</b>	<i>Variable Air Volume Modular Assembly (VMA) 1400 Series Application Note (LIT-6375125)</i>
<b>Using VMA Balancing Tool (VBT) Software</b>	<i>Using the VMA1400 Balancing Tool (VBT) Software Technical Bulletin (LIT-6363092)</i>
<b>Connecting Using CablePRO or CVTPRO</b>	<i>Auxiliary Gear Technical Bulletin (LIT-6363080)</i>



## Application Examples

**Note:** The examples in this document do not reflect all of the possible questions and answers. These examples provide a basic overview of wiring locations you might expect to see. They do not define all available applications.

### Single Duct Application Example 1

**Table 6: Single Duct Example 1 Questions**

HVAC PRO Software Questions	Configuration Selections
VAV Box Type	Pressure Independent, Single Duct
Fan Type (R2)	Series/On-Off
Baseboard Heat Type	None
Box Heat Type (R3 and R4)	2-stages
Lighting (R1)	Start Stop Output (as shown in Figure 4)

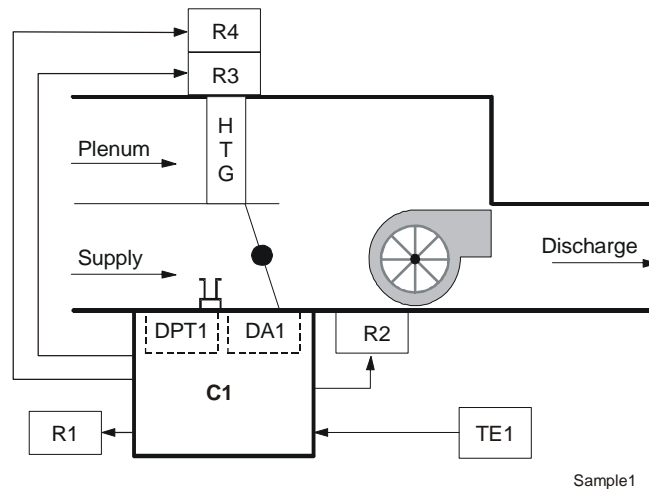

**Figure 3: Single Duct Example 1 Mechanical Flow Diagram**

**Table 7: Single Duct Example 1 Bill of Materials**

Component	Description	Part Number
C1, DPT1, DA1	VMA	AP-VMA1420-0
TE1	Temperature Sensor and Setpoint	TE-6700 Series
R1	Lighting Relay	GE-RR7
R2	Fan	*
R3, R4	Reheat Relays	*

\* Box OEM manufacturers typically furnish fan relays and electric heat relays.

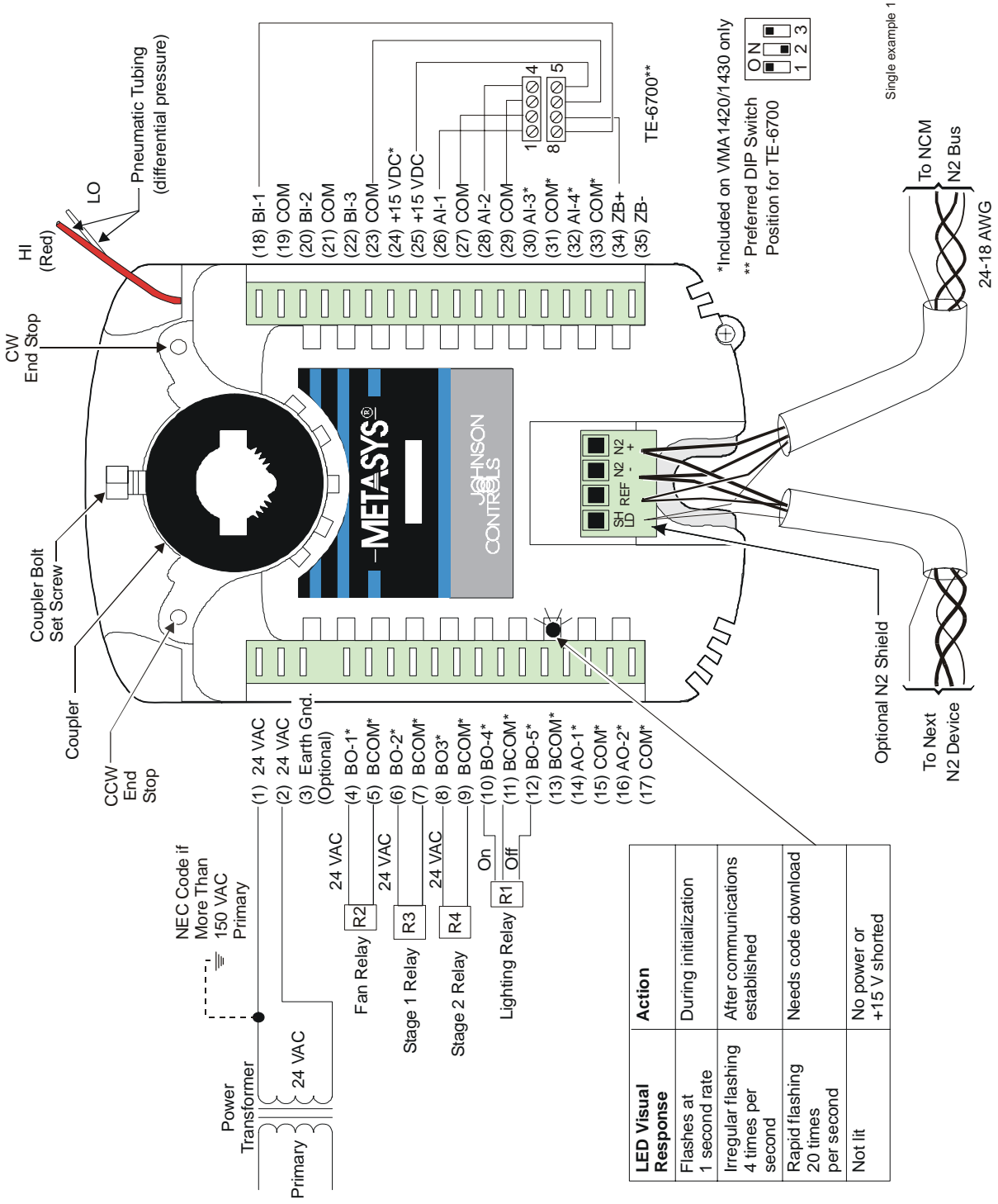

Figure 4: Single Duct Fan-Powered Box Example 1

### Single Duct Application Example 2

Table 8 illustrates the selections made through HVAC PRO software for this example.

**Table 8: Example 2 Questions**

HVAC PRO Software Questions	Configuration Selections
Control Strategy	Pressure Independent, Single Duct
Supply Damper Actuator (DA1)	Floating/3-wire
Fan Type (R)	Parallel Fan Temperature Controlled
Baseboard Heat Type (VA2)	Analog Output Valve
Box Heat Type (VA1)	Floating/3-wire
Warmup Initiation	Supply Air Temp Via a Hardware Input
Lighting Integration	No

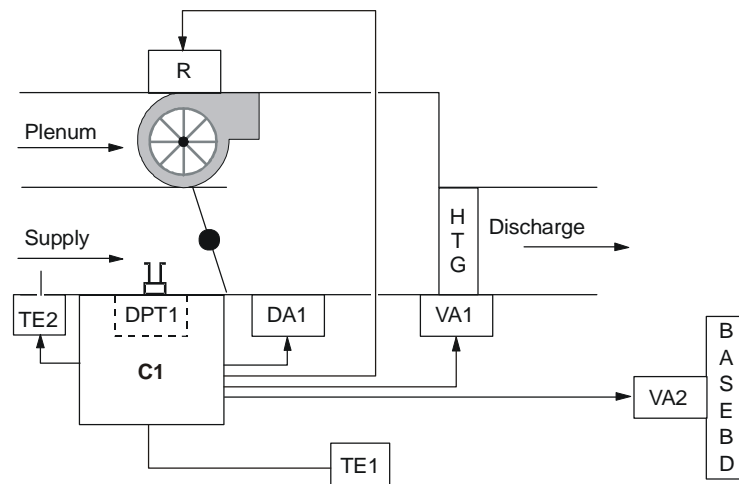

Sample3

**Figure 5: Single Duct Example 2 Mechanical Flow Diagram**

**Table 9: Single Duct Example 2 Bill of Materials**

Component	Description	Part Number
C1, DPT1	VMA	AS-VMA1430-0
DA1	Damper Actuator	Integrated with VAV box
TE1	Zone Temperature Sensor	TMZ1600
TE2	Supply Air Temperature Sensor	TE-6311P-1
VA1	Valve Actuator Box Heat	VA-8020-1
VA2	Baseboard Heat Valve Actuator	VA-8052
R	Fan	*

\* Box OEM manufacturers typically furnish fan relays and electric heat relays.

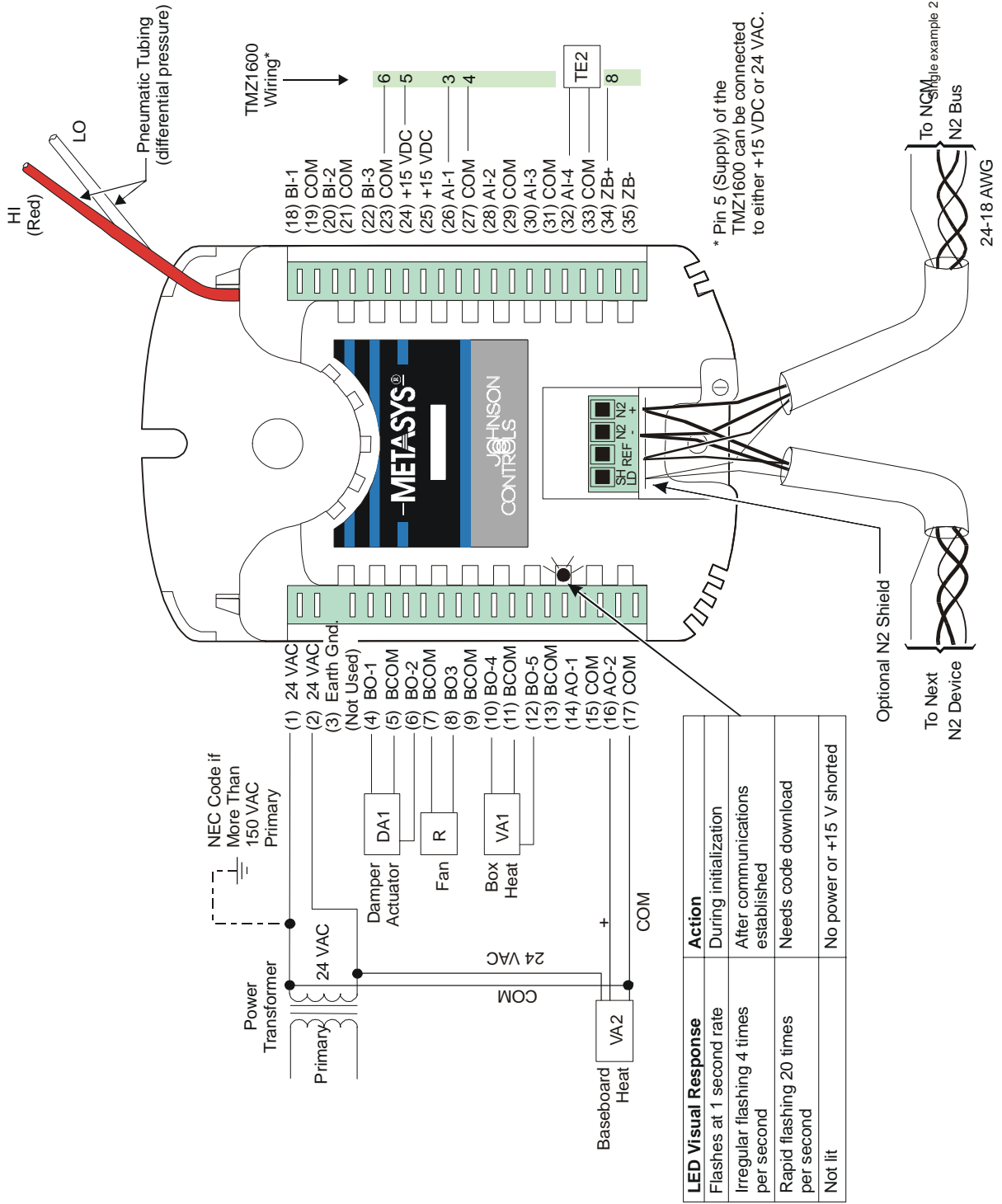

Figure 6: Single Duct Fan-Powered Box Example 2

**Single Duct Supply/Exhaust Application Example**

Table 10 illustrates the selections made through HVAC PRO software for this example.

**Table 10: Example Questions**

HVAC PRO Software Questions	Configuration Selections
Control Strategy	Pressure Independent, Supply/Exhaust
Supply Actuator	VMA Integrated Actuator
Fan Type	None
Exhaust Actuator (DA2)	Position Adjust Output (3-wire/floating)
Box Heat Type (VA1)	Analog Output
Baseboard Heat Type	None
Lighting Integration	None

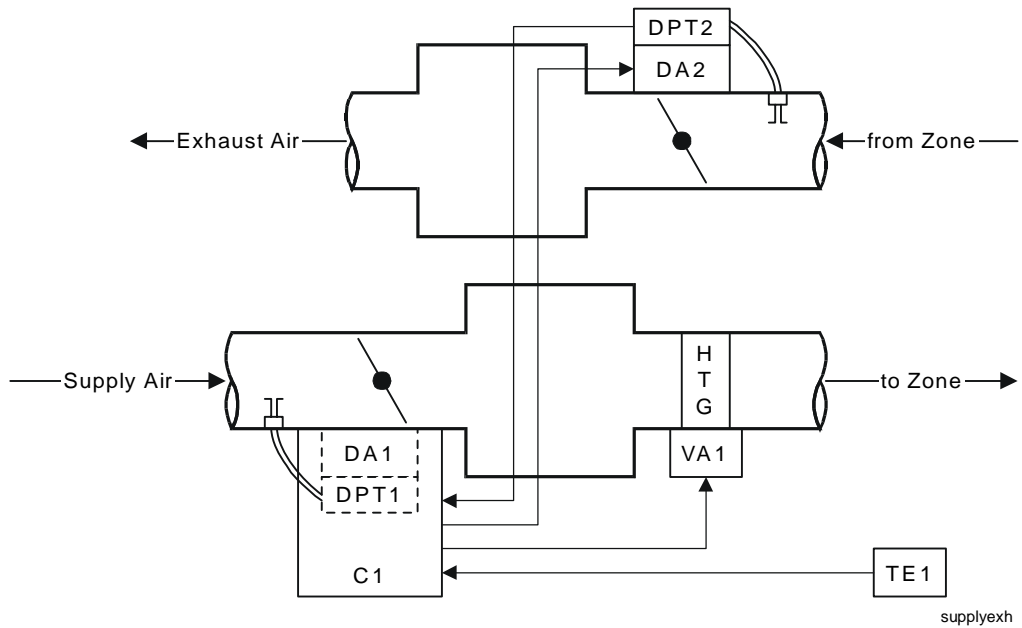

**Figure 7: Single Duct Supply/Exhaust Example Mechanical Flow Diagram**

**Table 11: Example Bill of Materials**

Component	Description	Part Number
C1, DPT1, DA1	VMA	AP-VMA1420-0
DPT2, DA2	External Actuator and Velocity Pressure Sensor	M9104-AGS-2N
VA1	Value Actuator Box Heat	VA-8020-1
TE1	Temperature Sensor and Setpoint	TE-6700 Series

### Single Duct Supply/Exhaust with BO Solenoid Application Example

Table 12 illustrates the selections made through HVAC PRO for Windows operating system for this example.

**Note:** This example only applies to HVAC PRO 8.05 or later.

**Table 12: Example Questions**

HVAC PRO Software Questions	Configuration Selections
Control Strategy	Pressure Independent, Supply/Exhaust with BO for Autocalibration Solenoid
Supply Actuator (DA1)	VMA Integrated Actuator
Fan Type	None
Exhaust Actuator (DA2)	Position Adjust Output (3-wire/floating)
Box Heat Type (VA1)	Analog Output
Baseboard Heat Type	None
Lighting Integration	None

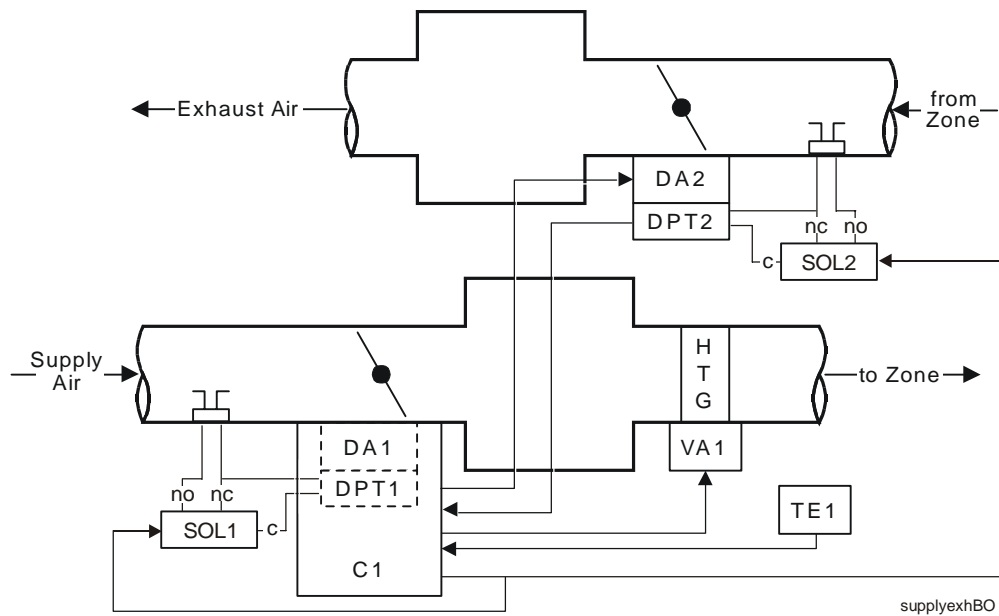

**Figure 8: Single Duct Supply/Exhaust with BO Solenoid Example Mechanical Flow Diagram**

**Table 13: Example Bill of Materials**

Component	Description	Part Number
C1, DPT1, DA1	VMA	AP-VMA1420-0
DPT2, DA2	External Actuator and Velocity Pressure Sensor	M9104-AGS-2N
SOL1, SOL2	MAC 3-Way Solenoid Air Valves	35A-FW-24VAC*
VA1	Value Actuator Box Heat	VA-8020-1
TE1	Temperature Sensor and Setpoint	TE-6700 Series

\* Part is available from Kele & Associates. For current information, consult the Web site at [www.kele.com](http://www.kele.com).

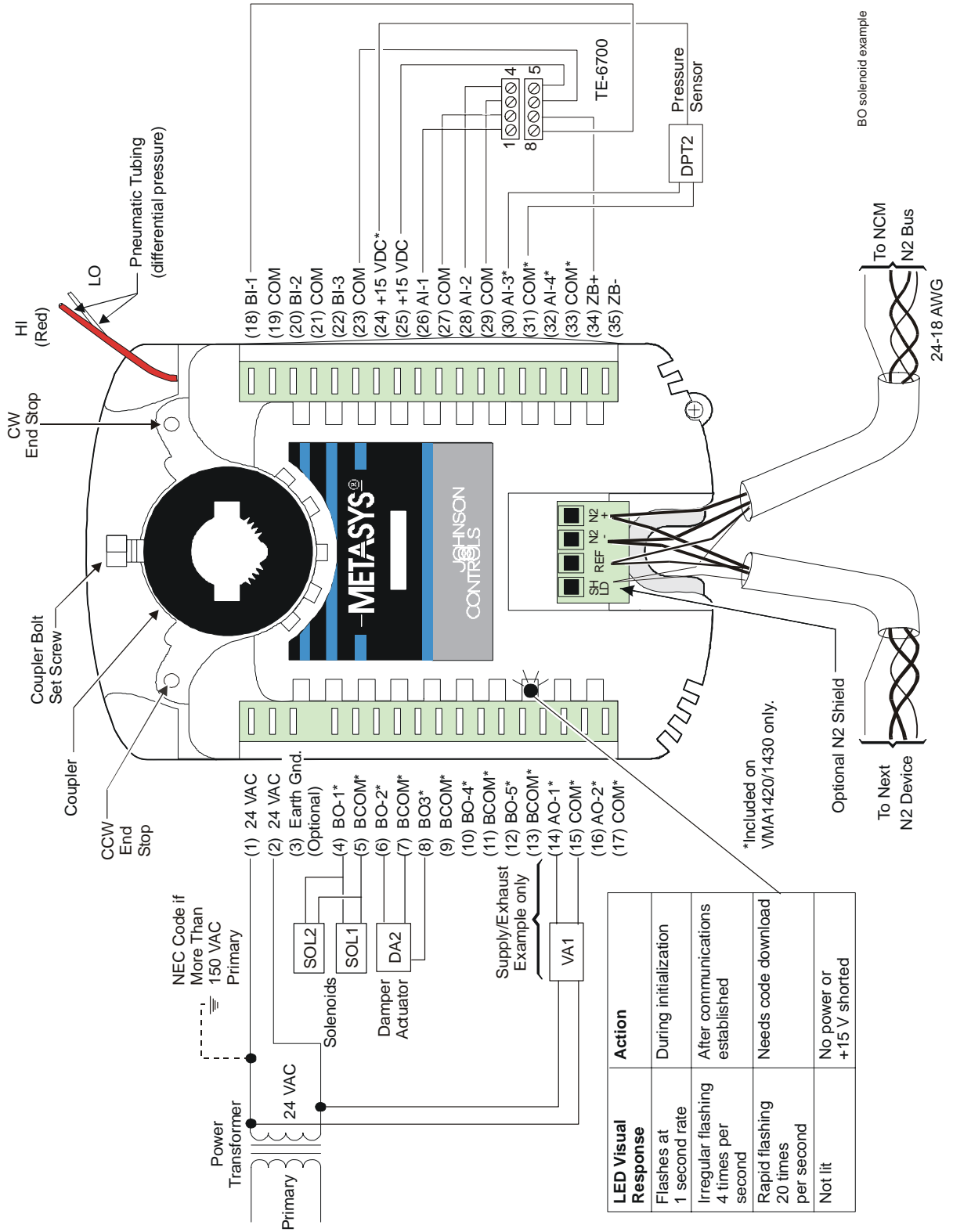

Figure 9: Single Duct Supply/Exhaust with BO Solenoid Example

### Dual Duct Application Example

Table 14 illustrates the selections made through HVAC PRO software for this example.

**Note:** This example only applies to HVAC PRO 8.0 or later.

**Table 14: Example Questions**

HVAC PRO Software Questions	Configuration Selections
Control Strategy	Pressure Independent – Variable Box Flow, Dual Duct
Discharge Air Sensor (TE2)	Yes
Cold Deck Actuator	VMA Integrated Actuator
Hot Deck Actuator (DA2)	Position Adjust Output (3-wire/floating)
Flow Sensor Locations (DPT1 and DPT2)	Hot and Cold Deck Flow
Baseboard Heat Type	None
Lighting Integration	None

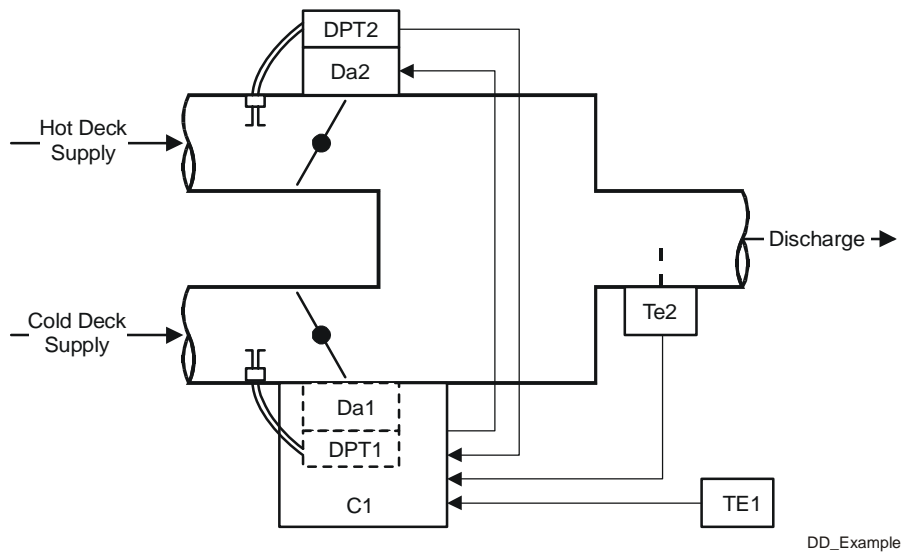

**Figure 10: Dual Duct Example Mechanical Flow Diagram**

**Table 15: Example 2 Bill of Materials**

Component	Description	Part Number
C1, DPT1, DA1	VMA	AP-VMA1420-0
DPT2, DA2	External Actuator and Velocity Pressure Sensor	M9104-AGS-2N
TE1	Temperature Sensor and Setpoint	TE-6700 Series
TE2	Discharge Air Temperature Sensor	TE-6300 Series



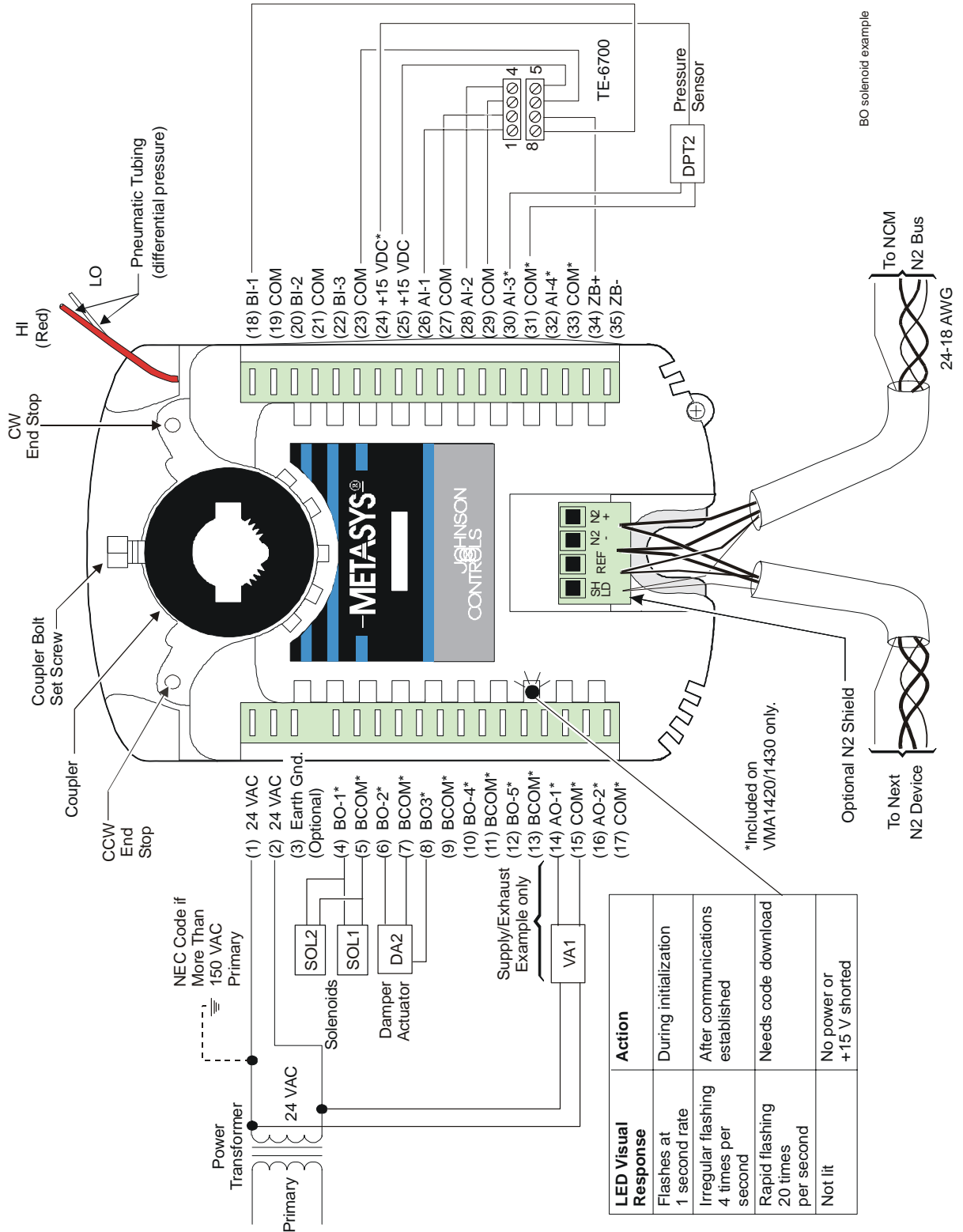

Figure 11: Dual Duct Example

## Reference Information

### VMA Parts List

Table 16: Available VMA Models

Inputs/Outputs	Points	Rating	VMA1410 (Cooling Only)	VMA1420 (Cooling w/Reheat)	VMA1430
<b>Analog Inputs</b>					
Zone Temperature	AI-1	1 K Ni, Si, or Pt or 2.25 K NTC	×	×	×
Zone Setpoint	AI-2	1.6 K ohm Potentiometer	×	×	×
Humidity, Dewpoint, Sideloop, or Velocity Pressure	AI-3	0-10 VDC		×	×
Supply Air Temperature or Supplemental Heat Temperature	AI-4	1 K Ni, Si, or Pt or 2.25 K NTC		×	×
Velocity Pressure	Internal	0-1.5 in. w.c./ 0-374 pa	×	×	×
<b>Binary Inputs</b>					
Temporary Occupied/ Standby	BI-1	Dry contact	×	×	×
Occupied	BI-2	Dry contact	×	×	×
Off or Window or Shutdown	BI-3	Dry contact	×	×	×
<b>Analog Outputs</b>					
Proportional Heat	AO-1	0-10 VDC @ 10 mA		×	×
	AO-2	0-10 VDC @ 10 mA		×	×
<b>Binary Outputs</b>					
Lights	BO-1 to	24 VAC Triac @ 0.5 A each		×	×
Fan	BO-5				
Box Heat--Valve or 1-3 stage Electric					
Supplemental Heat-- Valve or Single Stage Electric					
Box Heat					
External Damper Actuator					
Stepper Motor with Position Feedback	Internal	2-phase Stepper	×	×	

## Specifications

**Table 17: Specifications**

Feature	Specification												
<b>Product Name</b>	Variable Air Volume Modular Assembly (VMA)												
<b>Product Code Number</b>	<table border="0"> <tr> <td><b>Cooling Only Models:</b></td> <td><b>Cooling with Reheat and/or Fan Powered Models:</b></td> <td><b>Models without Actuators:</b></td> </tr> <tr> <td>Single Unit</td> <td>AP-VMA1420-0</td> <td>AP-VMA1430-0</td> </tr> <tr> <td>Bulk Pack</td> <td>AP-VMA1420-0D</td> <td>AP-VMA1430-0D</td> </tr> <tr> <td>Buy American</td> <td>AP-VMA1420-0G</td> <td>AP-VMA1430-0G</td> </tr> </table>	<b>Cooling Only Models:</b>	<b>Cooling with Reheat and/or Fan Powered Models:</b>	<b>Models without Actuators:</b>	Single Unit	AP-VMA1420-0	AP-VMA1430-0	Bulk Pack	AP-VMA1420-0D	AP-VMA1430-0D	Buy American	AP-VMA1420-0G	AP-VMA1430-0G
<b>Cooling Only Models:</b>	<b>Cooling with Reheat and/or Fan Powered Models:</b>	<b>Models without Actuators:</b>											
Single Unit	AP-VMA1420-0	AP-VMA1430-0											
Bulk Pack	AP-VMA1420-0D	AP-VMA1430-0D											
Buy American	AP-VMA1420-0G	AP-VMA1430-0G											
<b>Supply Voltage</b>	20-30 VAC at 50 or 60 Hz												
<b>Optional Fuse Current</b>	0.6 ampere for VMA1410; 2.0 ampere for VMA1420; 1.2 ampere for VMA1430												
<b>Power Consumption</b>	VMA1410/1420: 10 VA maximum (relay and valve requirements not included) VMA1430: 3 VA maximum (damper actuator, relay, and valve requirements not included)												
<b>Ambient Operating Conditions</b>	0 to 50°C (32 to 122°F)												
<b>Ambient Storage Conditions</b>	-40 to 70°C (-40 to 158°F)												
<b>Terminations</b>	6.3-mm (1/4-in.) spade lugs (Communication has screw terminals.)												
<b>Serial Interfaces</b>	N2 Bus and Zone Bus												
<b>N2 Controller Addressing</b>	DIP switch set (1-253) Addresses 254 and 255 are reserved. Software addressable with the HVAC PRO program Release 7.02 or later, or the VBT program												
<b>Communications Bus</b>	N2 between VMA and NCM/N30 (3-wire). Zone Bus between VMA and room sensor (8-pin phone jack or wire to spade lugs or optional plug-on terminals)												
<b>Mounting</b>	One screw (included) mounts the VMA1410/1420 to the VAV box. One screw attaches damper shaft to the actuator, 8-mm (5/16-in.) square head set screw with 44 N·m (375 lb·in) of axial holding power for up to 13-mm (1/2-in.) round damper shafts. Minimum damper shaft length is 44.5 mm (1-3/4 in.). Use two screws (included) to mount the VMA1430 to the VAV box.												
<b>Housing</b>	Plastic housing for controller/actuator with UL 94-5VB Plenum Flammability Rating												
<b>Dimensions (L x W x H)</b>	VMA1410/1420: 153 x 102 x 102 mm (6 x 4 x 4 in.) VMA1430: 153 x 102 x 83 mm (6 x 4 x 3.25 in.)												
<b>Actuator Torque</b>	4 N·m (35 lb·in) minimum (VMA1410/1420 only)												
<b>Shipping Weight</b>	VMA1410/1420: 13.1 kg (29 lb) for a box of ten, 1.3 kg (2.8 lb) each VMA1430: 5 kg (10.6 lb) for a box of ten, 0.5 kg (1.06 lb) each												
<b>Electrical Inputs</b>	<p>Analog Inputs:</p> <ul style="list-style-type: none"> <li>Nickel, silicon, or platinum (1 K ohm) or NTC (2.25 K) RTD room sensors, 1.6 K setpoint potentiometer (2-wire)</li> <li>Voltage input for 0-10 VDC (humidity or dew point sensor)</li> </ul> <p>Binary Inputs: Dry contacts Input configurations vary based on model type.</p>												
<b>Velocity Pressure Outputs</b>	<p>Velocity Pressure for 374 Pascal (0-1.5 in. w.c.)</p> <p>No outputs on VMA1410, except Stepper Motor</p> <p>Binary outputs: 24 VAC triac switched, 25-500 mA loads</p> <p>Stepper drive: 2 to 767 steps per second (23,000 step resolution) (VMA1410/1420 only)</p> <p>Analog output: 0-10 VDC @ 10 mA maximum</p>												
<b>Continued on next page . . .</b>													

<b>Feature (Cont.)</b>	<b>Specification</b>
<b>Standards Compliance</b>	CSA C22.2 No. 205 UL916, UL864 (UUKL), UL94-5VB FCC CFR47 Part 15, Subpart B, Class A and B Verified C-tick Australia, AS/NZS 4251.1 CE EMC Directive 89/336/EEC, (EN 50081-1, CISPR 11, Class B, EN 50082-2) IEEE 472, IEEE 518, IEEE 587 Category A/B
<b>Accessories</b>	AP-TBK1002-0* Removable 2-position screw terminal kit (100 pcs) AP-TBK1003-0* Removable 3-position screw terminal kit (100 pcs) M9000-106* Removable 4-position screw terminal (1 piece each) AP-TBK4N2-0 Replacement N2 Bus 4-position screw terminal kit (10 pcs)
	* These terminals fit over the existing I/O spade lugs.

### ***Federal Communications Commission Part 15 Label***

This equipment has been tested and found to comply with the limits for a Class A digital device pursuant to Part 15 of FCC Rules. These limits are designed to provide reasonable protection against harmful interference when this equipment is operated in a commercial environment. This equipment generates, uses, and can radiate radio frequency energy, and if not installed and used in accordance with the instruction manual, may cause harmful interference to radio communications. Operation of this equipment in a residential area is likely to cause harmful interference, in which case the user will be required to correct the interference at his/her own expense.

**Table 18: Additional Detailed VMA Specifications**

<b>Feature</b>	<b>Specification</b>
<b>Power Input</b>	
<b>Voltage Range</b>	20 to 30 VAC; 50 or 60 Hz
<b>Input Current</b>	0.5 Ampere without Relays or Valves
<b>Transient Protection</b>	Isolated from AI, BI, AO, ZBus, +15 VDC and N2 Bus; Common and Normal Mode Capacitor
<b>N2 Bus Communications</b>	
<b>Bus Type and Voltage</b>	RS-485 (Differential $\pm 5$ VDC)
<b>Bus Speed</b>	9600 Baud
<b>Transient Protection</b>	Isolated from 24 VAC, BOs, AI, BI, AO, ZBus, +15 VDC; PTC+Transorb; Common Mode Capacitors
<b>Zone Bus Communications</b>	
<b>Bus Type and Voltage</b>	RS-422 (Single-ended 5 VDC) or RS-485 (Differential $\pm 5$ VDC)
<b>Bus Speed</b>	1200 Baud
<b>Transient Protection</b>	Isolated from 24 VAC, BOs and N2; PTC+Transorb; Common Mode Capacitors
<b>Microprocessor/Memory</b>	
<b>Microprocessor</b>	8-bit Motorola® 68HC11 operating at 8 MHz
<b>Memory</b>	256 K byte FLASH PROM; 32K byte static RAM
<b>DC Supply Output</b>	
<b>Voltage Range</b>	13.5 to 18 VDC
<b>Load Current</b>	0 to 35 mA
<b>Overload and Transient Protection</b>	Current Foldback; Isolated from 24 VAC, BOs and N2 Bus; Common Mode Capacitors
<b>Pressure Input</b>	
<b>Range</b>	0 to 374 Pascal (0 to 1.5 in. w.c.)
<b>Proof Pressure</b>	6895 Pascal (1 psi)
<b>Burst Pressure</b>	68.9 K Pascal (10 psi)
<b>Resolution (15 bit)</b>	0.0151 Pascal (0.000061 in. w.c.)
<b>Non-Repeatability and Hysteresis</b>	$\pm 0.187$ Pascal ( $\pm 0.00075$ in. w.c. maximum)
<b>Non-linearity (Best Fit)</b>	$\pm 2$ Pascal ( $\pm 0.008$ in. w.c. maximum) for 0-249 Pascal ( $\leq 1$ in. w.c.) $\pm 3$ Pascal (0.012 in. w.c. maximum) for >249 Pascal ( $> 1$ in. w.c.)
<b>Thermal Effect on Zero*</b>	$\pm 0.1793$ Pascal per degree C ( $\pm 0.00040$ in. w.c. per degree F maximum)
<b>Thermal Effect on Span</b>	$\pm 0.1793$ Pascal per degree C ( $\pm 0.00040$ in. w.c. per degree F maximum)
<b>Position Effect on Zero*</b>	$\pm 0.623$ Pascal ( $\pm 0.0025$ in. w.c. maximum)
<b>Position Effect on Full Span</b>	$\pm 0.623$ Pascal ( $\pm 0.0025$ in. w.c. maximum)
<b>Long Term Zero Drift*</b>	$\pm 2.491$ Pascal per year ( $\pm 0.01$ in. w.c. per year maximum)
<b>Long Term Span Drift</b>	$\pm 2.491$ Pascal per year ( $\pm 0.01$ in. w.c. per year maximum)
<b>Sample Time</b>	One second
Continued on next page . . .	

<b>Feature (Cont.)</b>	<b>Specification</b>
<b>Temperature Inputs</b>	
<b>Range</b>	NTC: -20 to 105°C (-4 to 221°F) Nickel: -45 to 121°C (-50 to 250°F) Silicon: -40 to 102°C (-40 to 216°F) Platinum: -50 to 200°C (-58 to 392°F) Setpoint: 18 to 28°C (65 to 85°F)
<b>Resolution (15 bit)</b>	NTC: -17.7528°C (0.0034°F) Nickel: -17.7528°C (0.0449°F) Silicon: -17.7607°C (0.0307°F) Platinum: -17.7437°C (0.0614°F) Setpoint: -17.7772°C (0.0018°F)
<b>Non-Repeatability (estimate) and Hysteresis</b>	NTC: $\pm 0.011^{\circ}\text{C}$ ( $\pm 0.020^{\circ}\text{F}$ ) maximum Nickel: $\pm 0.100^{\circ}\text{C}$ ( $\pm 0.180^{\circ}\text{F}$ ) Silicon: $\pm 0.056^{\circ}\text{C}$ ( $\pm 0.10^{\circ}\text{F}$ ) maximum Platinum: $\pm 0.130^{\circ}\text{C}$ ( $\pm 0.234^{\circ}\text{F}$ ) Setpoint: $\pm 0.011^{\circ}\text{C}$ ( $\pm 0.020^{\circ}\text{F}$ ) maximum
<b>Measurement Accuracy</b>	NTC: $\pm 0.11^{\circ}\text{C}$ ( $\pm 0.20^{\circ}\text{F}$ ) maximum Nickel: $\pm 0.50^{\circ}\text{C}$ ( $\pm 0.90^{\circ}\text{F}$ ) maximum Silicon: $\pm 0.33^{\circ}\text{C}$ ( $\pm 0.60^{\circ}\text{F}$ ) maximum Platinum: $\pm 0.67^{\circ}\text{C}$ ( $\pm 1.20^{\circ}\text{F}$ ) maximum Setpoint: $\pm 0.06^{\circ}\text{C}$ ( $\pm 0.10^{\circ}\text{F}$ ) maximum
<b>Thermal Tolerance</b>	$\pm 0.010\%$ per degree C ( $\pm 0.018\%$ per degree F) maximum
<b>Long Term Drift</b>	$\pm 0.07\%$ per year maximum
<b>Sample Time</b>	One second
<b>Transient Protection</b>	Isolated from 24 VAC, BOs, and N2 Bus; Normal Mode RC; Common Mode Capacitors
<b>Voltage Input</b> (AP-VMA1420 and VMA1430)	
<b>Range</b>	0 to 16.5 VDC
<b>Resolution (15 bit)</b>	0.00053 VDC
<b>Non-Repeatability (estimate)</b>	$\pm 0.0055$ VDC maximum
<b>Measurement Accuracy</b>	$\pm 0.075$ VDC maximum
<b>Thermal Tolerance</b>	$\pm 0.018\%$ per degree C ( $\pm 0.032\%$ per degree F) maximum
<b>Long Term Drift</b>	$\pm 0.7\%$ per year maximum
<b>Sample Time</b>	One second
<b>Transient Protection</b>	Isolated from 24 VAC, BOs and N2 Bus; Normal Mode RC; Common Mode Capacitors
<b>Binary Inputs</b>	
<b>Voltage Range and Trigger Level</b>	BI-1: 0 to 5 VDC with 3.1 VDC threshold BI-2/BI-3: 0 to 15 VDC with 2.5 VDC threshold
<b>Sample Time</b>	50 ms pulse width (10 Hz maximum)
<b>Transient Protection</b>	Isolated from 24 VAC, BOs and N2 Bus; Normal Mode RC; Common Mode Capacitors

Continued on next page . . .

<b>Feature (Cont.)</b>	<b>Specification</b>
<b>Analog Outputs</b>	(AP-VMA1420 and VMA1430)
<b>Voltage Range</b>	0 to 10 VDC
<b>Load Current</b>	0 to 10 mA
<b>Voltage Resolution (12-bit)</b>	0.002 VDC
<b>Non-Repeatability (estimate)</b>	$\pm 0.02$ VDC maximum
<b>Voltage Tolerance</b>	$\pm 0.20$ VDC maximum
<b>Thermal Tolerance</b>	$\pm 0.018\%$ per degree C ( $\pm 0.032\%$ per degree F) maximum
<b>Long Term Drift</b>	$\pm 0.7\%$ per year maximum
<b>Time Constant</b>	One second
<b>Transient Protection</b>	Isolated from 24 VAC, BOs, and N2 Bus; Common Mode Capacitors
<b>Binary Outputs</b>	(AP-VMA1420 and VMA1430)
<b>Voltage Range</b>	20 to 30 VAC
<b>Load Current</b>	25 to 500 mA
<b>Time Constant</b>	50 ms
<b>Transient Protection</b>	Isolated from AI, BI, AO, ZBus, +15 VDC, and N2 Bus; Normal Mode Capacitors
<b>Stepper Motor Actuator Output</b>	
<b>Rated Running Torque</b>	4 N·m (35 lb·in) minimum
<b>Unpowered Holding Torque</b>	5.1 N·m (45 lb·in) minimum
<b>Stall Torque</b>	10.3 N·m (90 lb·in) maximum
<b>Stroke</b>	93 degrees maximum
<b>Angular Velocity</b>	3 degrees per second nominal
<b>Full Stroke Life</b>	150,000 cycles minimum
<b>Reposition Stroke Life</b>	2,500,000 cycles minimum
<b>Reposition Tolerance</b>	$\pm 1$ degree maximum
<b>Thermal Tolerance</b>	Zero, due to digital feedback
<b>Long Term Drift per Year</b>	Zero, due to digital feedback
<b>Acoustic Noise</b>	35 dB <sub>A</sub> at one meter maximum

\* Can be corrected using the Autocalibrate function.

Note: All specifications are for the VMA controller, DPT sensor, and internal actuator only, when measured at the midpoint of each range within 90 days of calibration at room temperature (approximately 70°F).

## Detailed Procedures

### Determining VAV Box Requirements

To determine VAV box requirements:

1. Select the VMA based on control sequence, Input/Output (I/O), side loops, and flow measurement accuracy requirements.
2. Establish sensor placement in zones.
3. Contact box manufacturer's representative to authorize mounting or mount on site. Consider the following:
  - VAV box must have hard stops on either the open or closed position.
  - damper shafts protruding less than 44 mm (1-3/4 in.) from the box are not acceptable for the VMA1410 and VMA1420.
  - shaft bushings may interfere with level mounting of the VMA1410 and VMA1420.
  - project install date
  - plans and specifications
  - wiring diagrams and specifications to box manufacturer
  - who does what: including mounting, connecting, downloading, testing, shipping
  - who provides what parts, including control enclosure and transformer
4. Coordinate field or factory mounting.

### Establishing the Room Schedule

To establish the room schedule:

1. Develop application configuration files based on project requirements. For flow calculation constants, refer to *Appendix B: VAV Controller Flow Calculation Constants Application Note (LIT-6375185)*.
2. Determine control strategy.
3. Select appropriate room sensors based on project specifications.

**Note:** The VMA does not support sensor sharing. Each VMA requires its own sensor. If you attempt to share the sensor, the VMA will not read the sensor value correctly, resulting in poor control.



4. Create source power drawings. Determine such things as line length, transformer count and layout, and power distribution.
5. Determine number of:
  - VMAs
  - room sensors
  - damper actuators (VMA1430 or dual duct)
  - differential pressure sensors (dual duct only)
  - valves
  - valve actuators
  - other control devices
  - transformers
  - phone cables
  - communication cables
  - accessories such as plug-on screw terminals

## Developing the Bill of Material and Placing Orders

To develop the bill of material and place orders:

1. Make sure the following items are included as required:
  - VMAs
  - room sensors (one per VMA)
  - damper actuators (VMA1430 or dual duct)
  - differential pressure sensors (dual duct only)
  - valves
  - valve actuators
  - box fan speed controllers - for information about the Johnson Controls® S66 Series Electronic Fan Speed Control, refer to the *S66 Series Electronic Fan Speed Control Product/Technical Bulletin (LIT-121605)*.
  - cables
  - transformers

The differential pressure sensor is part of all VMAs (1410, 1420, 1430). The damper actuator is part of the VMA1410/1420. A separate damper actuator is required for a VMA1430. VMAs cannot share room sensors.

Dual duct applications require one additional damper actuator and differential pressure sensor. The actuator M9104-AGS-2N is a combination of these components.

If VMAs are installed on an N2 Bus connected to an NCM, the NCM requires a minimum of 4 MB of memory.

2. Coordinate parts ordering and delivery, including:

- placing orders through Johnson Controls Customer Service
- determining shipping destinations
- coordinating VMA manufacturing and delivery issues
- coordinating box manufacturer issues
- coordinating boxes with VMAs delivered to job
- determining status of software, documentation, and drawings

**Note:** The VMA can be shipped in individual packages or bulk shipped (maximum 10 VMAs per box). Separate product codes define your order preference.

## Configuring the VMA

To configure the VMA:

1. Refer to the appropriate room schedule for room specifications.
2. Assign the N2 address for each device.
3. Using the HVAC PRO tool (EURO PRO tool in Europe), select control sequences. Refer to the *HVAC PRO User's Guide*. The VMA1410/1420 are downloaded with HVAC PRO software, Release 7.00 or later. The VMA1430 must be downloaded with HVAC PRO software, Release 7.02 or later.
4. Create individual HVAC PRO (EURO PRO in Europe) configuration files for each device or each set of similar devices.
5. Archive and document the applications and VMA configuration as needed for the supervisory controller database (Metasys system Release 9.0 or later). Downloading occurs through the N2 Bus.

Refer to the *Variable Air Volume Modular Assembly (VMA) 1400 Series Application Note (LIT-6375125)* for additional configuration information.



**Controls Group**  
507 E. Michigan Street  
P.O. Box 423  
Milwaukee, WI 53201

[www.johnsoncontrols.com](http://www.johnsoncontrols.com)  
Published in U.S.A.